



Design and performance of a microsecond time-resolved photo-CIDNP add-on to a Varian INOVA600 NMR spectrometer

Ilya Kuprov (Oxford)
Martin Goez (Halle)
Peter Hore (Oxford)



Oxford, 2006

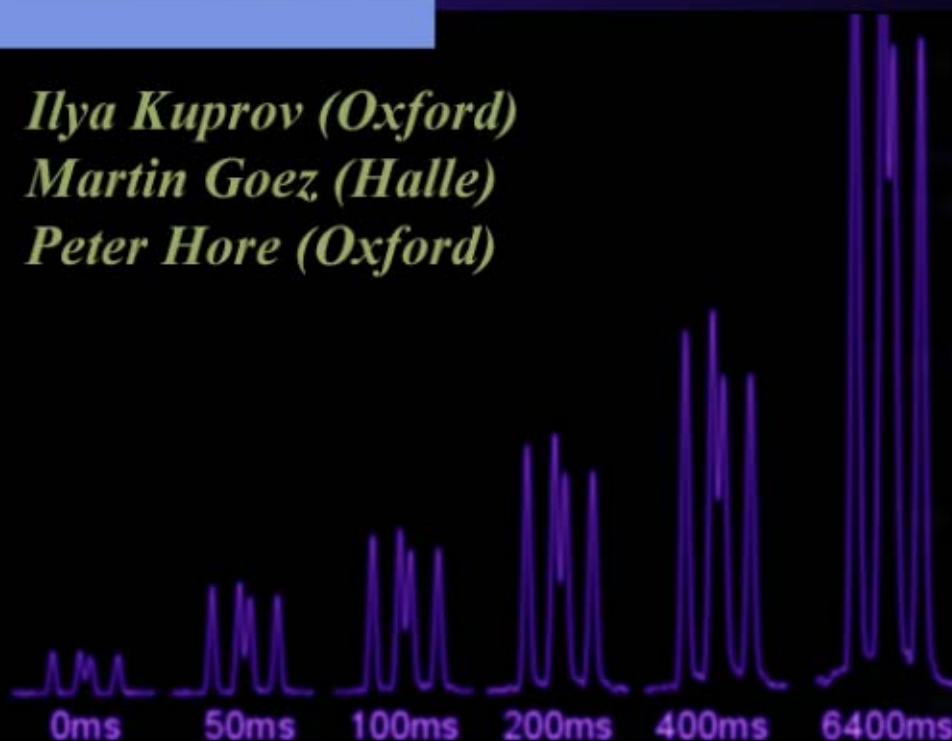

Chemically Induced Dynamic Nuclear Polarization (CIDNP)

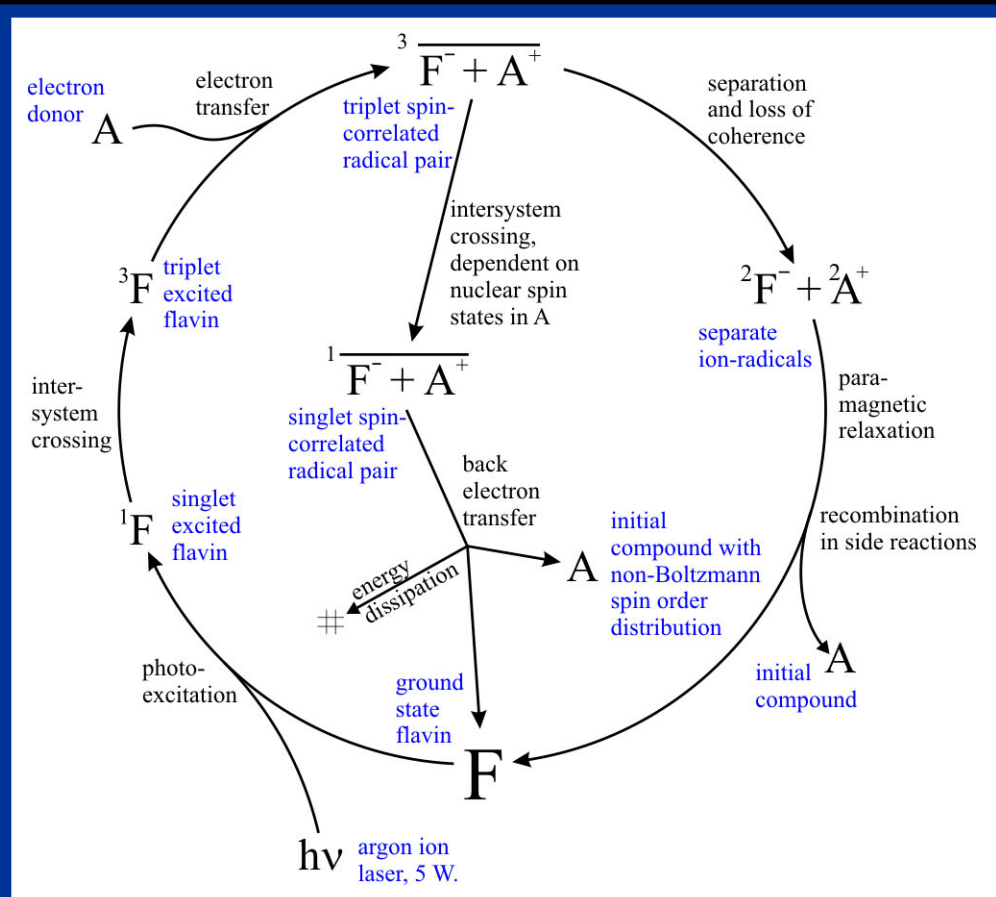

Most popular photosensitizers:

flavins (200-500 nm):

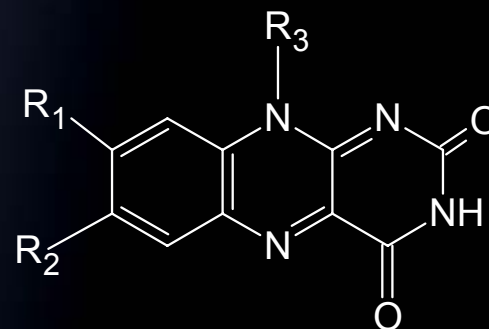

2,2'-bipyridyl (200-350 nm):

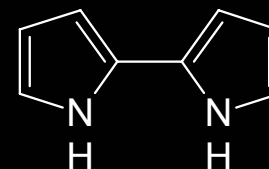

Target molecules:

aromatic amino acids, nucleotides, solvent-accessible aromatic side chains in proteins, solvent-accessible aromatic rings in DNA/RNA, phenols, thiols, etc.

CIDNP was discovered by Bargon and Fischer, and, independently, by Ward and Lowler in 1967. It has been recognized as a (rather exotic) sub-field of magnetic resonance ever since.

CIDNP: origin and manifestation.

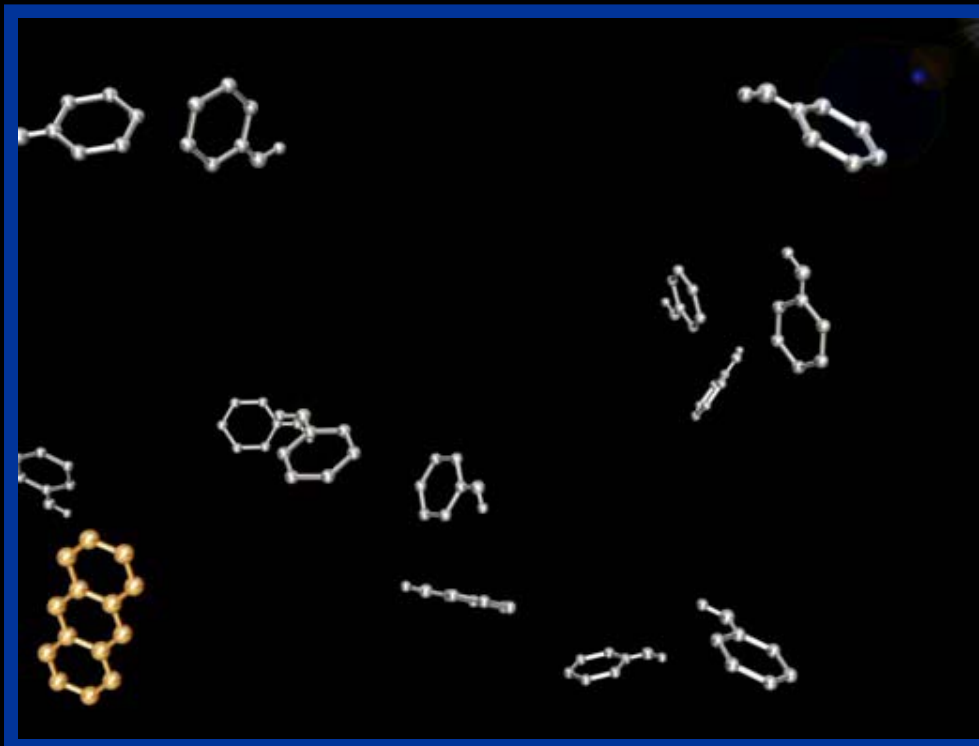

Origin: Different recombination probability of singlet and triplet spin-correlated radical pairs, and modulation of singlet-triplet interconversion by hyperfine interactions.

Manifestation: strongly enhanced ($\times 10$ to $\times 100$) NMR emission or absorption, sometimes with significant population of longitudinal multi-spin orders.

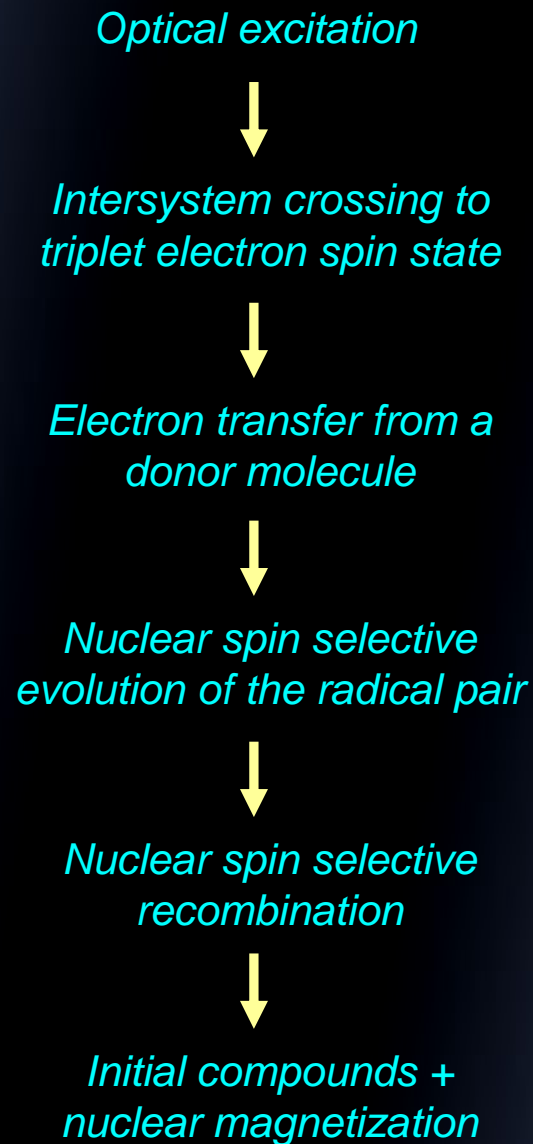

Chemical pumping of nuclear magnetization.

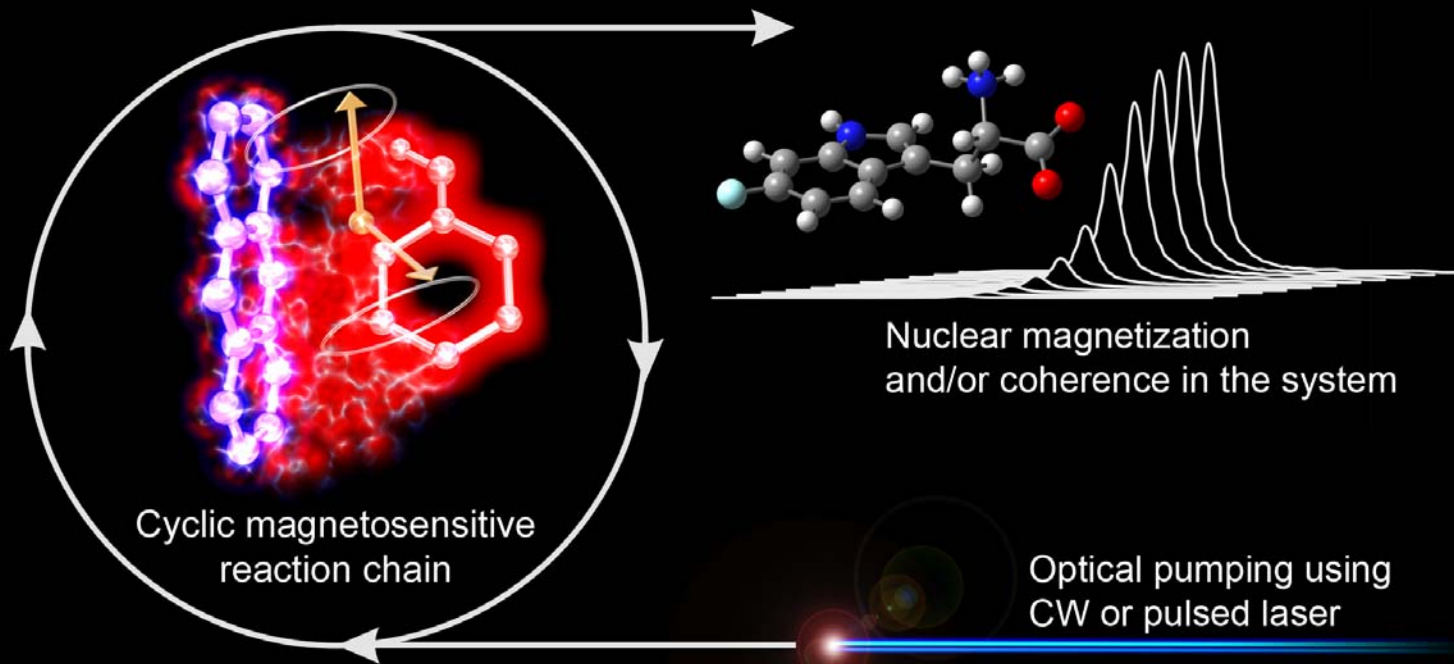

Origin: Radical recombination probability modulation by nuclear hyperfine interactions.

Applications:

- Protein folding and surface structure investigation.
- Chemically pumped nuclear magnetic resonance.
- Free radical structure and kinetics investigation.

TR-CIDNP system: design challenges



Wanted: a versatile, robust and inexpensive photochemical NMR setup, compatible with a shared NMR spectrometer, field gradients, cryoprobes, pulsed and continuous wave lasers.

Problems:



Light delivery: very intense laser light needs to be brought to the coil region of the NMR probe.



Laser control: pulsed solid-state lasers must be running throughout the pulse sequence and the relaxation delay at a constant repetition rate.



Laser synchronization: laser events must be synchronized with the pulse sequence with sub-microsecond accuracy.



Sequence programming: RF events must be “wrapped around” laser cycles. Sub-microsecond photochemistry timing must be programmed around rof delays on the low level.

NMR sample illumination problem – history.

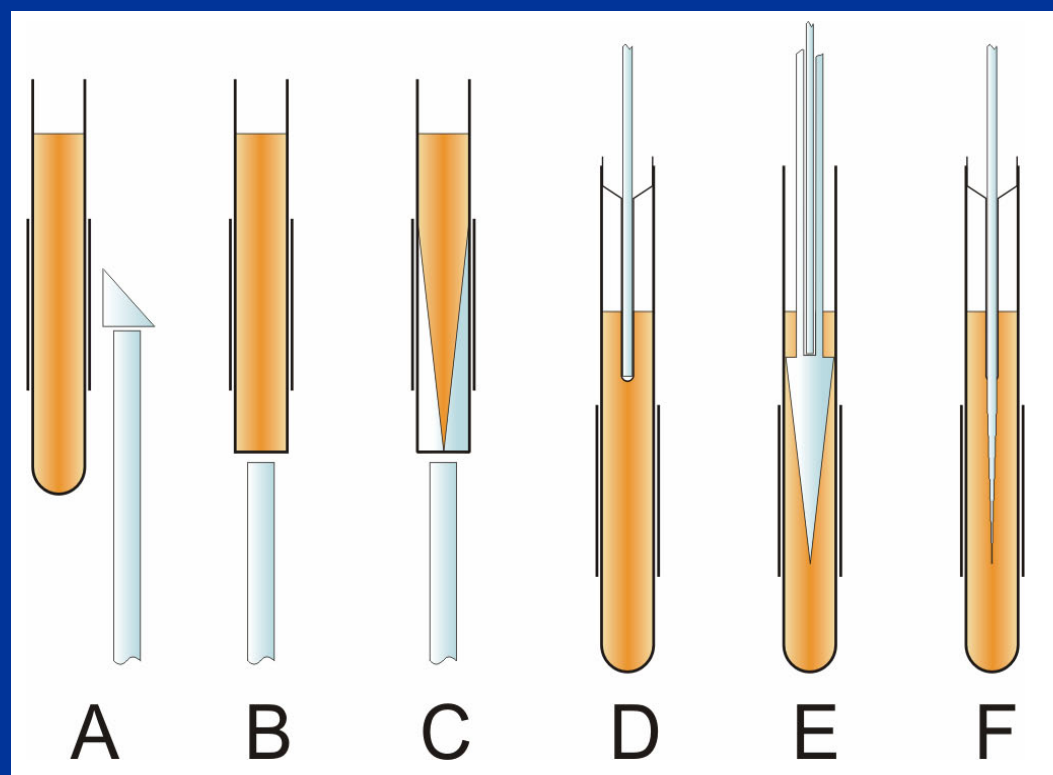

Continuous-wave sources: relatively straightforward, using the Berliner setup. Illumination uniformity used to be a problem. Severe resolution degradation with optically dense samples.

Pulsed sources: extremely difficult, normally requires probe modification. Bespoke probes expensive. Used to be impossible with multi-coil and cryoprobes.

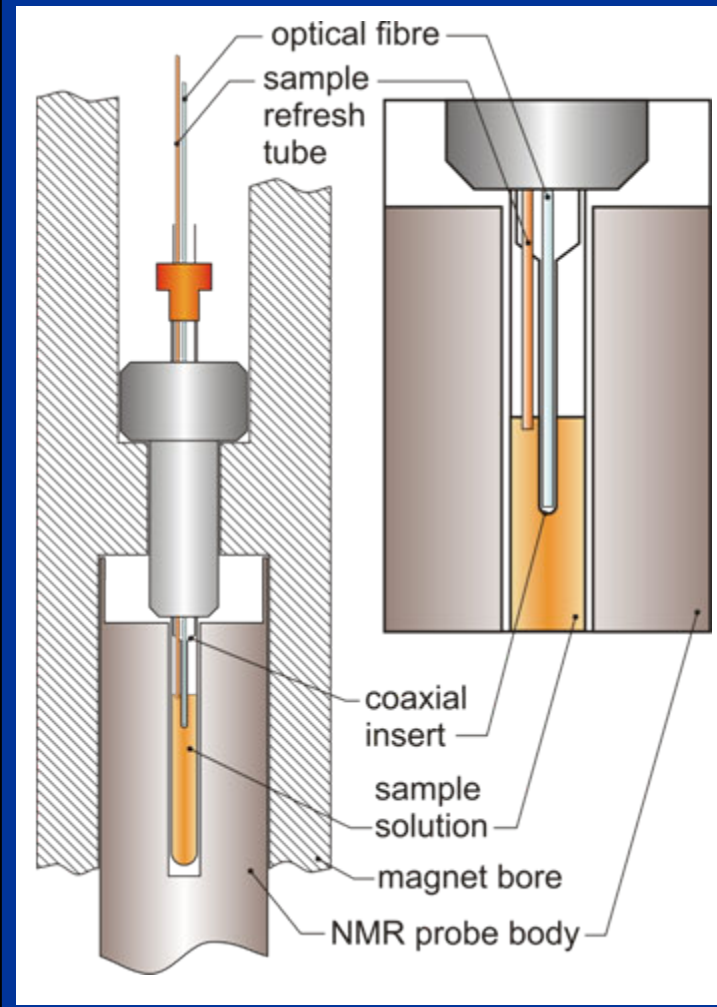

“Berliner setup”: an optical fibre held inside a coaxial insert – a *de facto* standard for CW CIDNP research.

Uniform CW illumination – problem solved

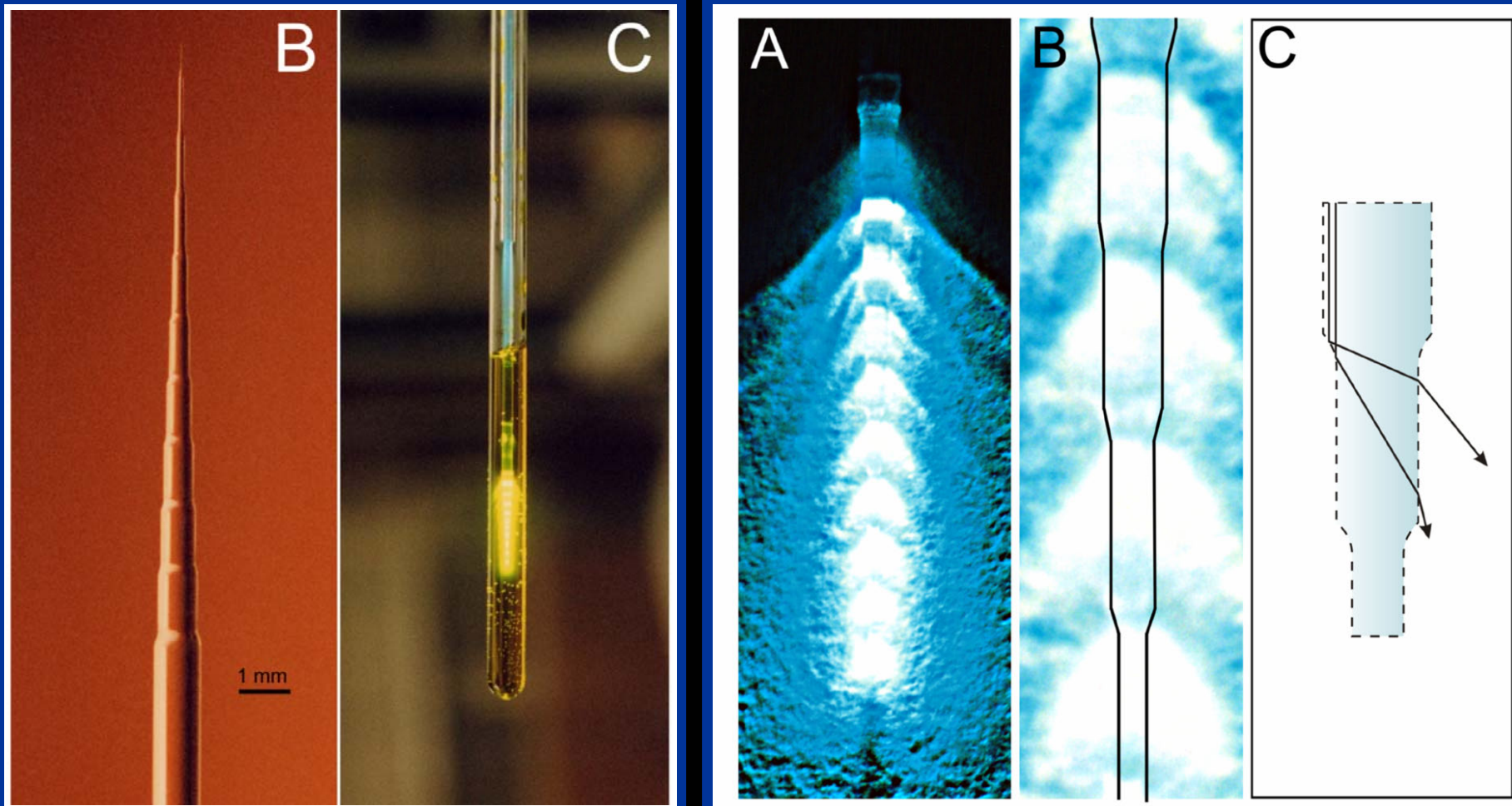

Based on HF-etched fused silica optical fibre, uniformly illuminates the sample “from within”, doesn’t lead to noticeable resolution or filling factor loss.

I. Kuprov, P.J. Hore, J. Magn. Res. 171 (2004) 171-175.

Uniform CW illumination – problem solved

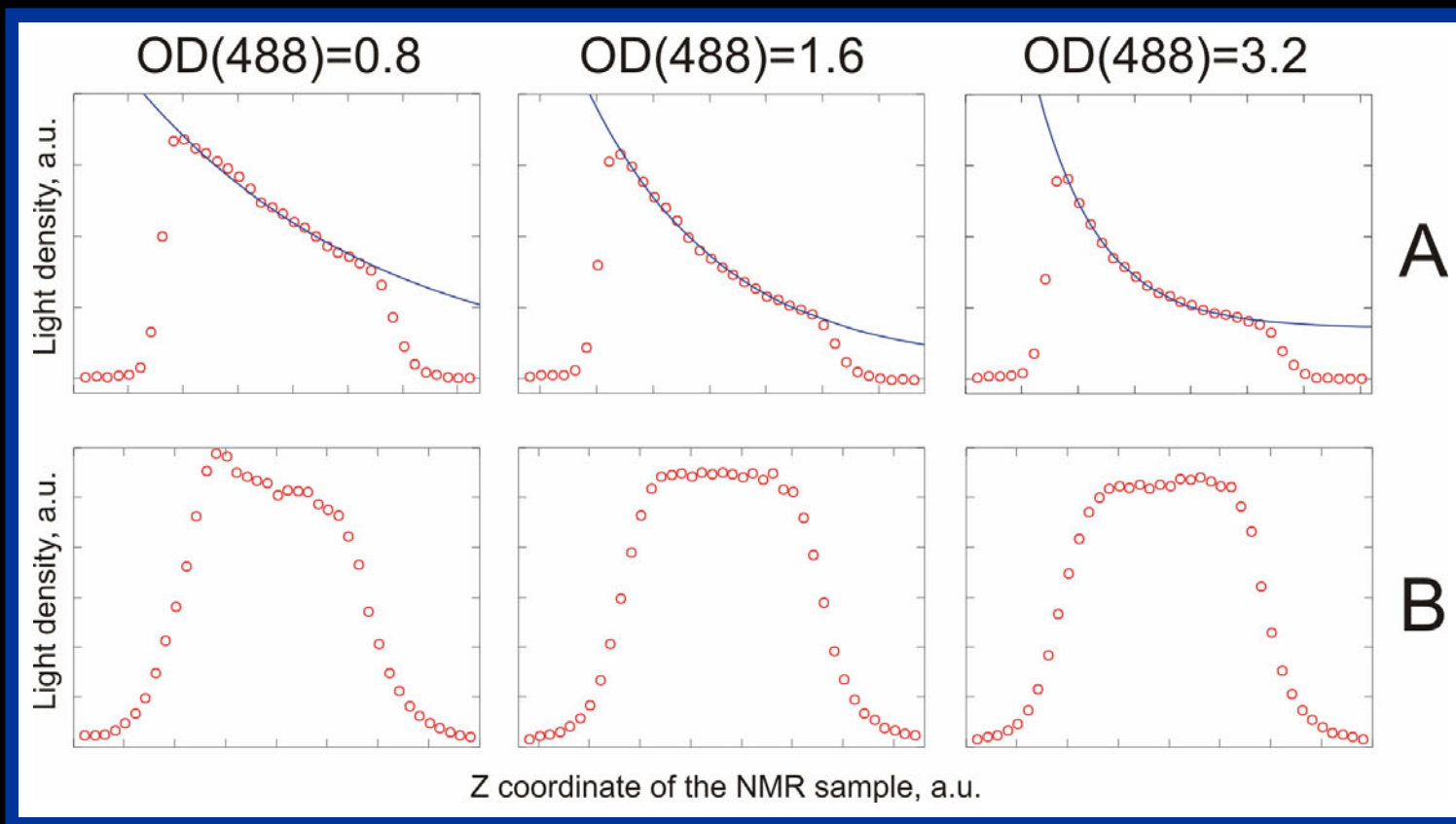

In certain regimes the amplitude of the ^{19}F photo-CIDNP effect is proportional to the amount of light that reaches the sample. It is thus possible to map the light intensity distribution using CIDNP combined with NMR imaging techniques.

Nanosecond pulsed illumination: our take

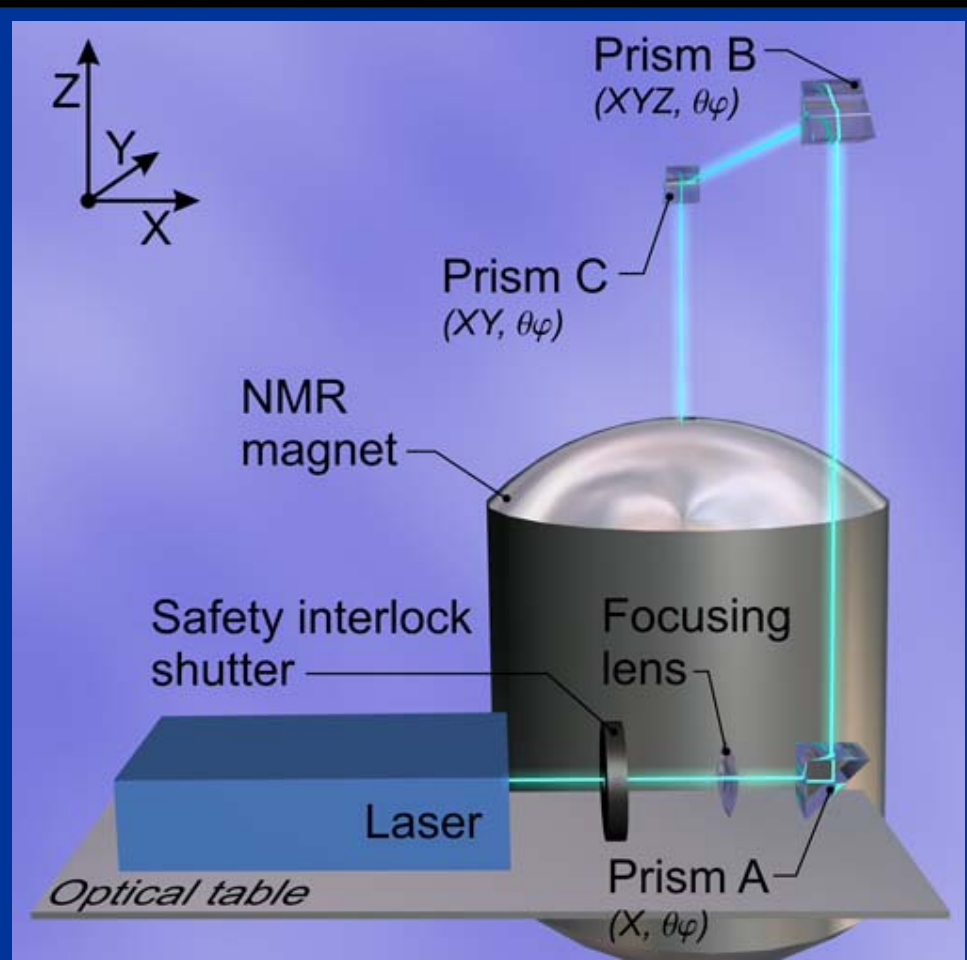

Basic principle: it looks like the only way left is from the top. The only viable way to bring the pulsed light in appears to be through-space routing by a series of prisms (mirrors in the latest incarnation).

100 mJ in 8 ns
equals
12.5 megawatts

Microsecond time-resolved photo-CIDNP installation

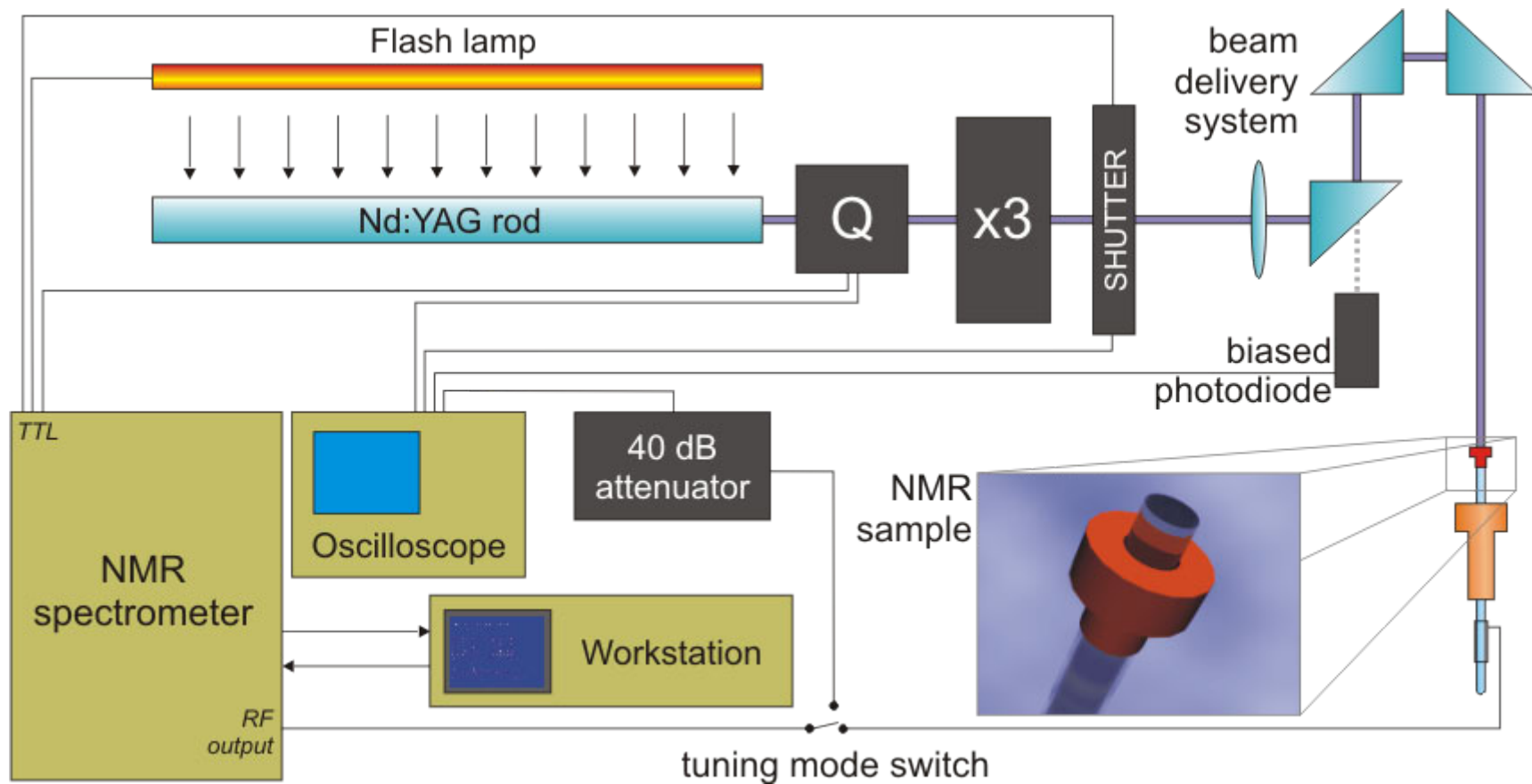

Probe modification is not required. Easily installable on any spectrometer, including ones equipped with cryoprobes.

*I. Kuprov, M. Goetz, P.A. Abbott, P.J. Hore, Rev. Sci. Instr. 76 (2005) 084103.
M. Goetz, I. Kuprov, P.J. Hore, J. Magn. Reson. 177 (2005) 146-152.*

The hard bit: software

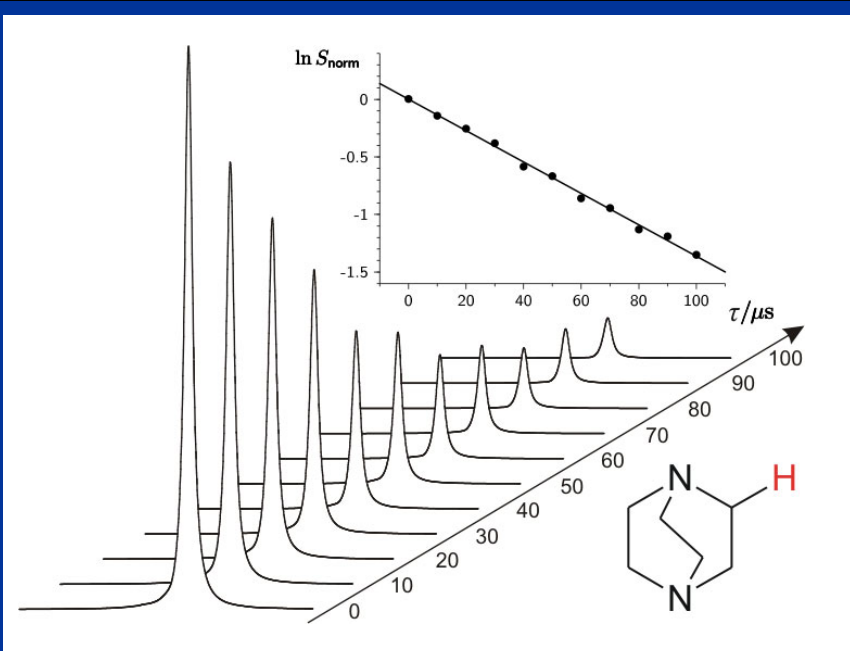
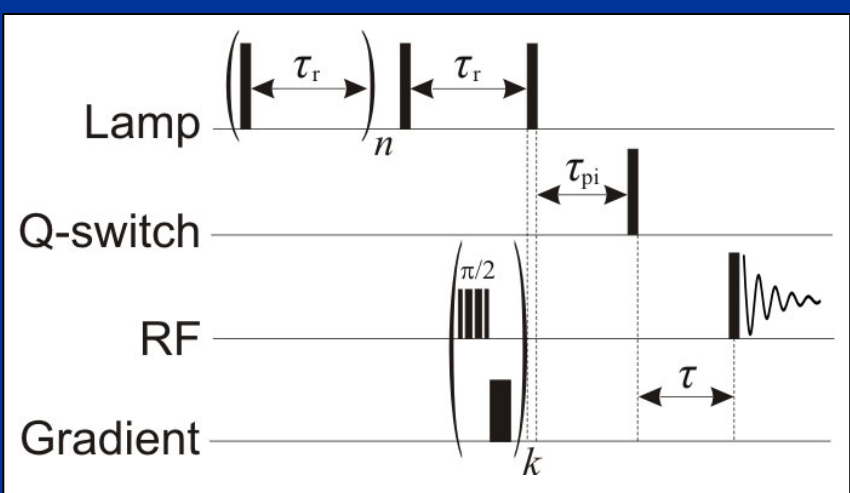

Basic pulse sequence requirements:

- Laser must be running continuously at 10-100 Hz, the rest of the sequence needs to be “wrapped” around laser control statements.
- RF pulse statement must be coded at the low level to ensure compatibility with *rof1* delay.
- Very high quality pre-suppression required.
- External equipment (laser lamp and Q-switch) must be synchronized with sub-microsecond accuracy.
- The observe pulse must be as short as possible, but as close to 90° as possible.

Current system specifications:

- 100 mJ, 7 ns pulse @ 355 nm @ 10 Hz
- $1\mu s$ $^1H/^{19}F$ observe pulse ($\sim 30^\circ$ flip angle)
- 1-5 μs $^{13}C/^{15}N$ observe pulse
- hotspot diameter: 3.5 mm
- hotspot drift: < 0.3 mm/day

Multi-flash TR-CIDNP sequence by Martin Goez

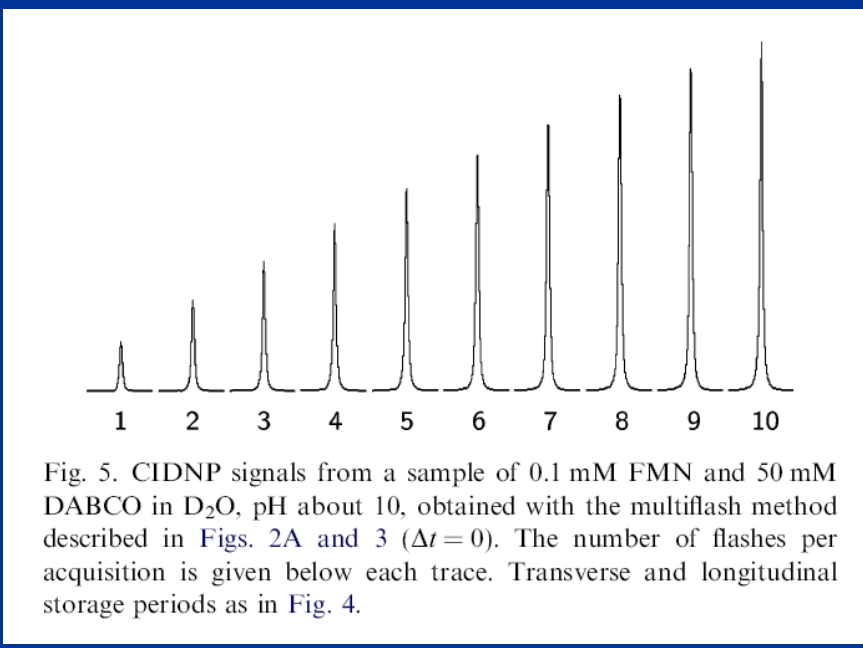
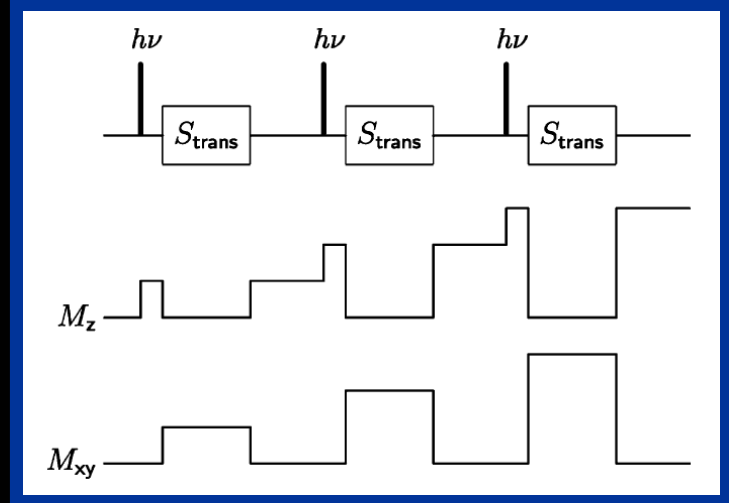
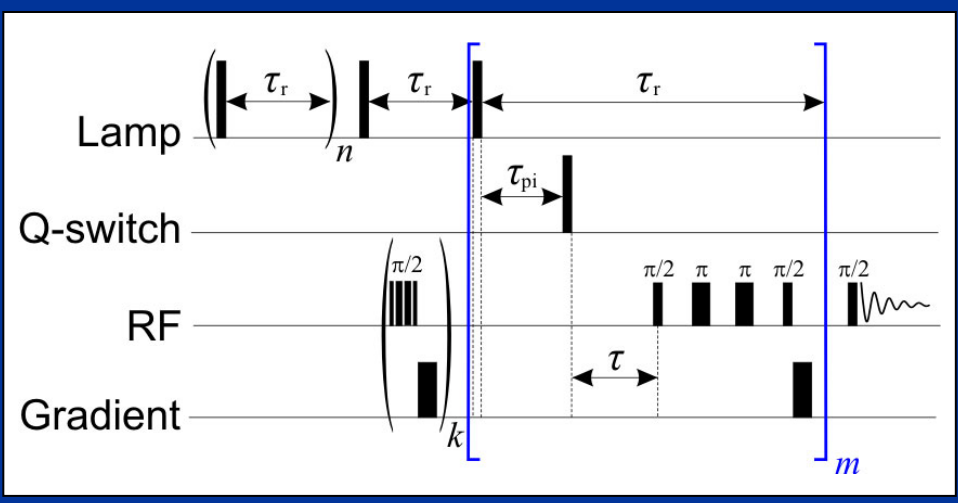

Multi-flash TR-CIDNP pulse sequence:

- Performs magnetization storage in the XY plane between laser flashes.
- Yields *linear* signal increase with the number of flashes (there used to be a square root).
- Can be, and was extended to longitudinal multi-spin orders (Mol. Phys., in press).
- Nested *for* loops, in-sequence mathematics, multiple *if* and *switch* statements, Varian C-based sequence language really shines!

So what can you do with it?

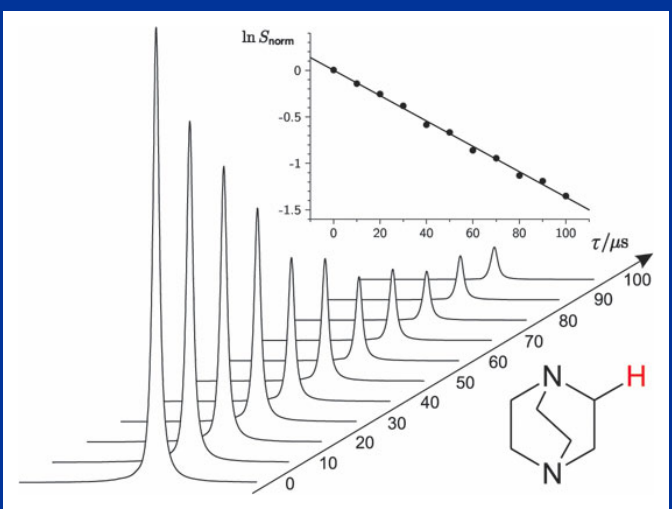

Extract the inter-radical degenerate electron transfer rate.
Kinetics predicted to be exponential. That's precisely the case.

Extract the hyperfine couplings in short-lived intermediates.



Extract the nuclear paramagnetic relaxation rates in short-lived radical intermediates.



Experimental T_1 : $0.3 \pm 0.1 \mu\text{s}$
Calcd T_1 ($\tau_c=100 \text{ ps}$): $0.18 \mu\text{s}$

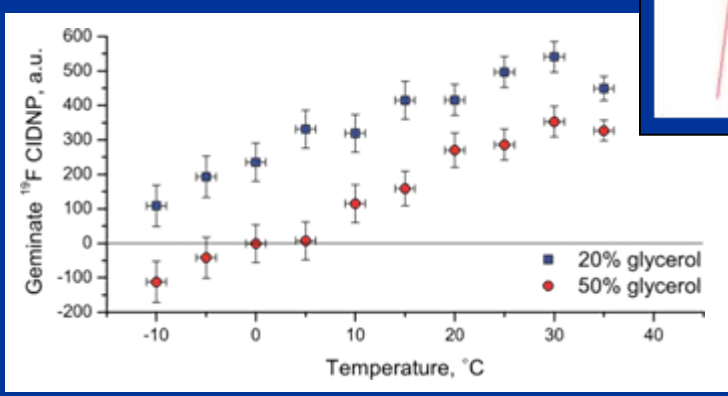
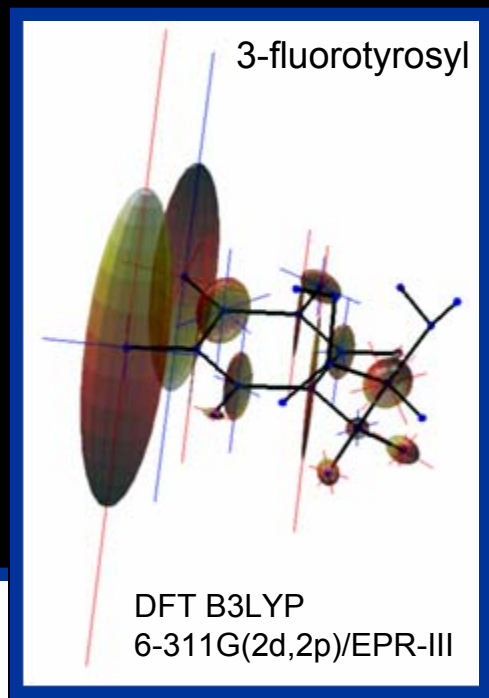
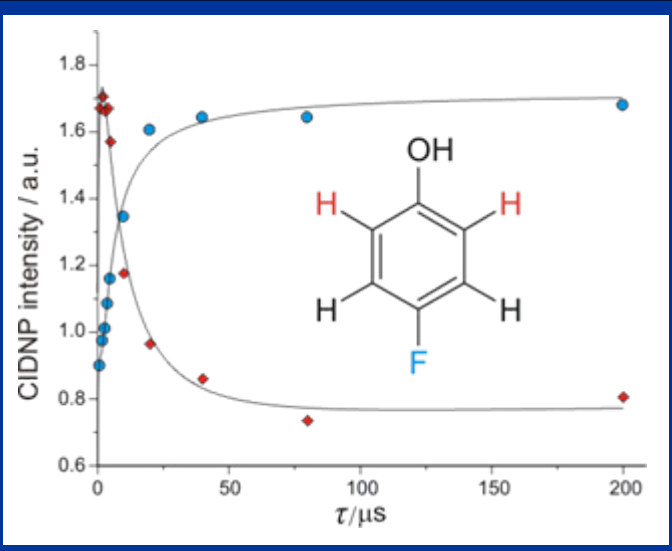

Study new relaxation phenomena...



There will be a separate talk in a few days at the ENC, devoted to applications.

Transverse Δg - Δh_{fc} cross-correlation in ^{19}F CIDNP

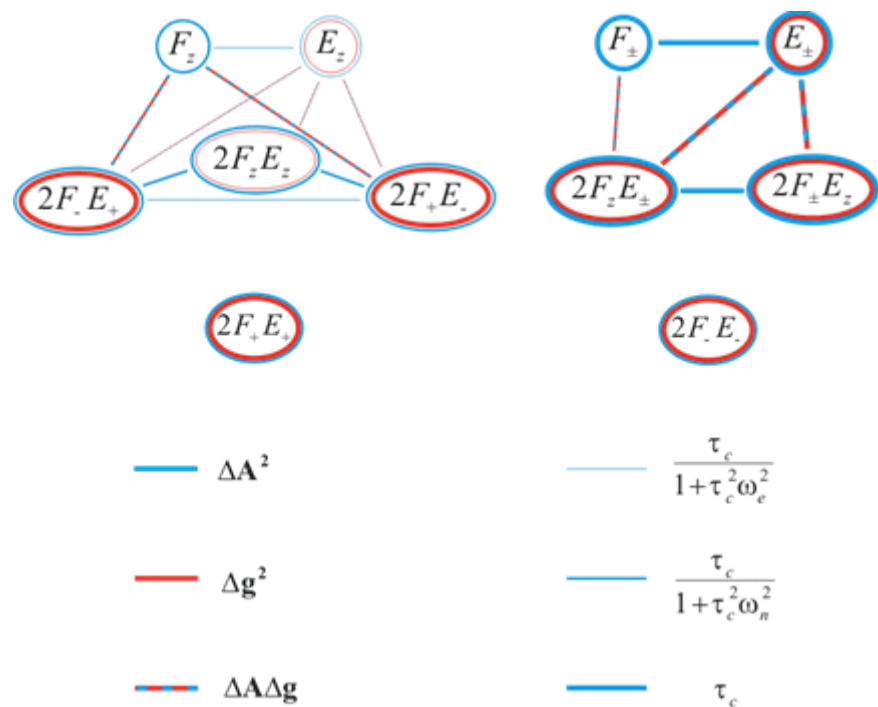
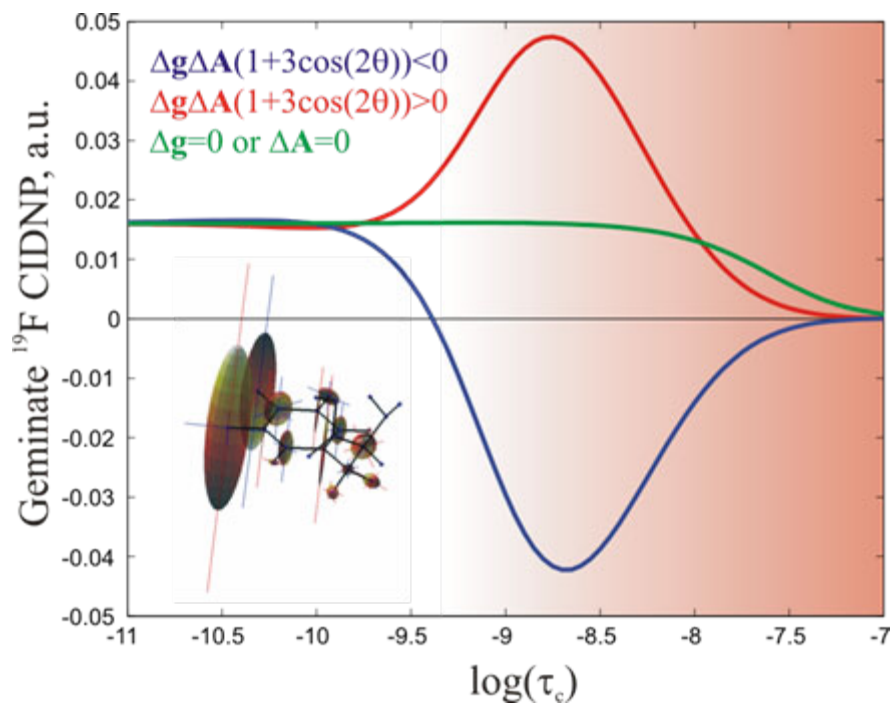

Simulation details:

- Exponential propagator solution with the full relaxation matrix in a complete Liouville space.
- Hyperfine anisotropy, g-tensor anisotropy and g-HFC cross-correlation included.
- Noyes' re-encounter statistics.

The brute-force simulation does predict the experimentally observed geminate ^{19}F photo-CIDNP sign change at long correlation times. Cool. Now need to hunt down the pathway responsible...

Acknowledgements

Collaborators:

Martin Goez (Halle, Germany)

Peter J. Hore (Oxford, UK)

Technical support:

Paul Bowyer (Varian)

Andrew Martin (Varian)

Funding:

Scatcherd European Foundation

Hill Foundation